

# A Guide To Stunning Handmade Curtains & Blinds

## 1 Choose your heading



### Pencil Pleat

Just the right touch of classic simplicity.



### Cottage Pleat

Perfect for creating a charming country feel.



### Pinch Pleat

A formal choice with elegant proportions.



### Tailored Pleat

New to our range, this clean inverted pleat heading offers understated simplicity.



### Roman Blind - Velcro

A classic window treatment – ideal for kitchens and bathrooms.



### Roman Blind - Pole

Specially designed to work with our range of handcrafted curtains poles.

## 2 Choose your fabric

Select from over 180 fabrics on our website. Each fabric is individually priced and can also be bought by the metre. Free fabric swatches are available to order from our website, or call us on 01473 826685 and we will pop them in the post for you.



## 3 Unlined, Lined or Interlined?



### Unlined

Creates an airy effect; ideal for voiles or soft linens.



### Lined

Choose from 3 neutral colourways. A blackout option is also available.



White Ivory Cream Blackout



### Interlined

Our recommended choice for stunning curtains – interlining makes any fabric look its best.

## 4 Measure

Measure-up using our step by step guide and call one of our friendly sales team. 01473 826685.

## How To Measure Curtains & Blinds

### How to measure for curtains

We recommend that you put up your pole before taking your measurements.

#### Width:

Measure the pole not the window itself. Measure the width between the decorative finials.

#### Length:

Please measure from the bottom loop of the curtain ring to the required length. We will add 3cm above the loop to your measurement.

**For sill length** measure to your desired length below the sill.

**For full length** measure to the floor or longer if desired.

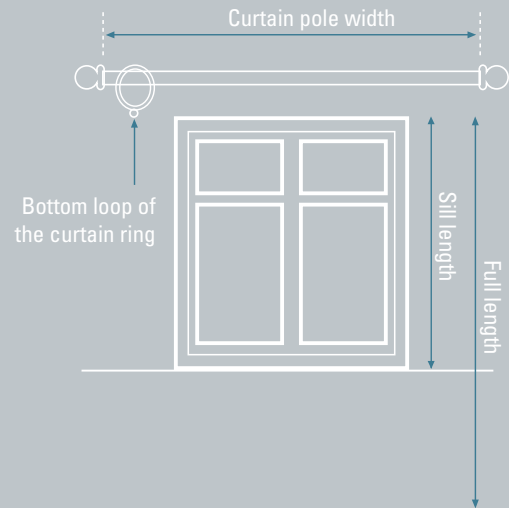

### How to measure for blinds

Outside a window recess.

#### Length:

When using a pole, measure from the bottom loop of the curtain ring to the required length. When using a batten, measure from the top edge of the batten to the required length.

#### Width:

When using a pole please measure from the outside edge of each bracket once they have been fixed in place. When using a batten add approximately 14cm to the width of your window to allow sufficient overlap.

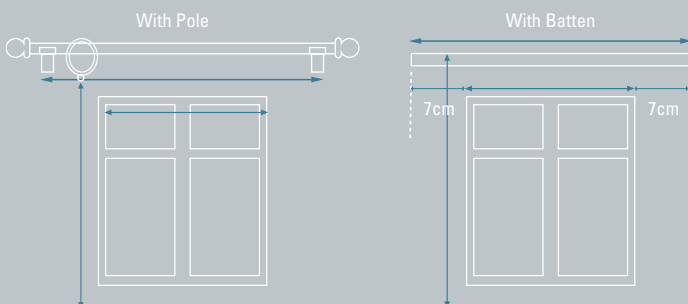

Inside a window recess.

We recommend that a batten is used for blinds hung inside a window recess. The blind will be supplied with a self-adhesive Velcro heading and screw eyes (and the batten).

#### Length:

Measure the length from the top to the bottom of the recess.

#### Width:

Measure the width at the top of the window recess, in the middle and at the bottom. Record the smallest measurement of the three to ensure the blind does not snag when being lowered. See the example below.

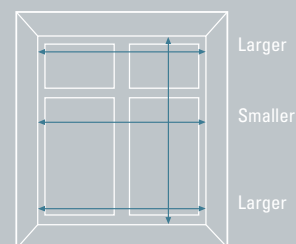

NB: Please let us know if you need your blind strung to the right or to the left.